



UNICOcoder[®] MP

Singlejet consumption meter
with M-Bus interface EN 13757-2
for warm water up to 90°C
DN 15, 20

Our strength: Your benefit

- Mechanical roller register with 1-litre-resolution:
Efficient consumption monitoring in energy data management
- Transfer of the effective meter reading:
No data loss and guaranteed security of the billing data
- Register without batteries:
No service life restriction
- Robust, high grade wear resistant materials:
Excellent measuring stability and reliability
- Measurement of low flow rates:
Increased cost effectiveness

Application

- Residential consumption monitoring of water consumption within an entire building
- Water meter with M-Bus data communication

Options

- M-Bus peripheral devices
- 1" NPSM connection thread on meter

Features

- Singlejet dry-dial meter with magnetic coupling
- 8 dial resolution with 3 comma place
- Register can be turned for best readout position
- Maximum operating pressure PN 16 bar
- Maximum operating temperature 90°C
- Horizontal or vertical installation
- High grade wear resistant and corrosion proof materials
- Inlet strainer
- Recyclable execution
- **CE** Conformity according to European Measuring Instruments (MID)
- Serial M-Bus-Interface to EN 13757-2 and M-Bus-Protocol EN 13757-3
- Power is provided from the M-Bus central
- Connecting cable, standard length 1,5m

GWFCoder[®]-Technology

The 2nd generation

The well-established GWFCoder[®]-system reads the absolute mechanical register value precisely and reliably and provides the data through standardized interfaces. The number wheels with three various long, asymmetrically arranged slots are being scanned through light pipes which are connected to five light emitting diodes (LED). Thus, the exact position of each number wheel can be detected and the encoded absolute register read can be transmitted as part of the M-Bus protocol. This functioning principle is patented by GWF. The GWFCoder[®]-interface provides an incomparably higher level of information compared to meters with pulse output.

GWF enhanced the reliable technology in its 2nd generation, so that 8 instead of 5 number wheels are being scanned and therefore a resolution of 1 liter is possible.

Documentation: HRE-CH - EPe10125



Installation

Pipeline:	horizontal	—
	vertical	
Meter head:	upwards	↑
	sideways	←→

Dimension Diagram

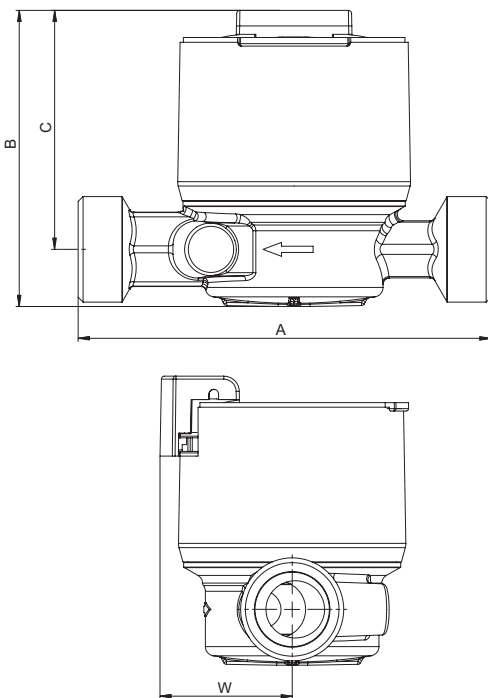

Technical Data

			15	20	20	20
Nominal diameter	DN	mm	15	20	20	20
Nominal pressure	PN	bar	16	16	16	16
Connection thread on meter	G...B	Inch	¾	1	1	1
Connection thread on coupling	R...	Inch	½	¾	¾	¾
Nominal flow rate	Q ₃	m ³ /h	2,5	2,5	2,5	4
Maximum flow rate	Q ₄	m ³ /h	3,125	3,125	3,125	5
Partial limit horizontal ±3%	Q _{2h}	l/h	50	50	50	80
Partial limit vertical ±3%	Q _{2v}	l/h	100	100	100	160
Minimum flow rate horizontal ±5%	Q _{1h}	l/h	31,3	31,3	31,3	50
Minimum flow rate vertical ±5%	Q _{1v}	l/h	62,5	62,5	62,5	100
Kvs-value		m ³ /h	3	3	3	5
Temperature		max. °C	90	90	90	90
Measuring range horizontal			R80	R80	R80	R80
Measuring range vertical			R40	R40	R40	R40

Dimensions and weights

			110	110	130	130
Length without couplings	A	mm	110	110	130	130
Length with couplings		mm	184	202	222	222
Height	B	mm	94	94	94	94
Height from pipe centre line	C	mm	76	76	76	76
Installation depth from pipe centre line	W	mm	43	43	43	43
Weight without couplings		app. g	690	720	770	710
Weight with couplings		app. g	830	950	1000	940

Permissible ambient temperature UNICOcoder® MP	+5°C to +55°C
Current consumption	max. 2 M-Bus Loads
M-Bus-Interface / -Protocol	EN 13757-2/-3
Standard transmission speed	2400 baud (optional 300 baud)
Register protection class	IP67

Certifications

UBA brass	x	x	x	x
KTW / W270	x	x	x	x
NSF-61-G	-	-	x ¹⁾	-
WRAS	x	-	x	x

¹⁾ only 1" NPSM execution

Measuring error curve

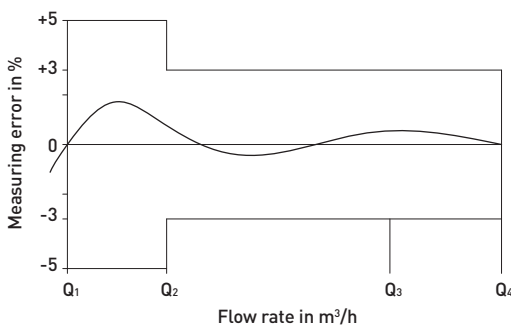

GWF
swiss.smart.simple.

Typical Head Loss Curve

