



## WI-N

### Irrigation Woltman meters for loaded water

Strongly loaded water, for example in agriculture, wastewater treatment plants, or sewage works requires especially robust meters that are also working reliably under difficult conditions. Our irrigation meters achieve this by having their measuring insert arranged in the upper part of the pipe where, in flowing water, usually only few suspended particles are found. The meter can easily handle a load ratio of up to 30%. We recommend an addition of external filters in front of the meter for very strong load.

The factory tested measuring insert is the same for all meter sizes and is available in the following measuring accuracies:

Q<sub>max</sub>-Q<sub>t</sub>: ± 3% (Value Class A+B)

Q<sub>t</sub>-Q<sub>min</sub>: ± 5% (Value Class A)

The roller counter is fully encapsulated and therewith protected from impurities. The meters are serially available with a lockable metal protecting cover, which reliably protects the counter under rough conditions.

Retrofitting with active and passive pulsers is possible at any time without damaging the calibration seal. All common sensor variations are available with Reed sensors, optical and inductive-NAMUR sensors; the integration in data communications and automation and control systems is therewith simple.

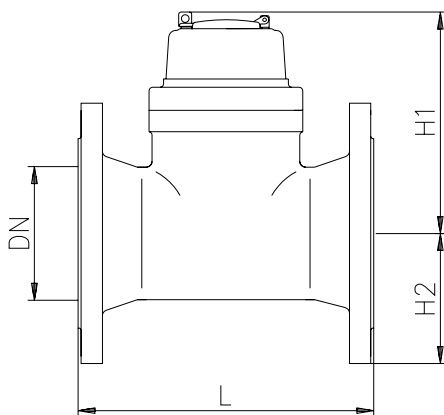

Dimensions WI-N

### Performance characteristics in overview

- Meter for loaded water or as a control meter for raw water
- Easy to maintain through removable measuring insert
- Measuring accuracy corresponding to Class A
- For horizontal and vertical installation position

Technical data WI-N									
Nominal flow	Qn	m³/h	30	50	90	125	175	250	450
Nominal diameter	DN	mm	50	65	80	100	125	150	200
Overall length	L	mm	200	200	225	250	250	300	350
Measuring accuracy			A	A	A	A	A	A	A
Maximum flow (short-term)	Qmax	m³/h	100	120	150	300	350	500	900
Maximum flow (constant)		m³/h	70	120	120	300	300	500	800
Transitional flow	Qt	m³/h	6	12	12	30	30	50	80
Minimum flow	Qmin	m³/h	2,4	4,8	4,8	12	12	20	32
Display range	min	l	0.5	0.5	0.5	0.5	0.5	0.5	0.5
	max	m³	9.999.999	9.999.999	9.999.999	9.999.999	9.999.999	9.999.999	9.999.999
Maximum temperature		°C	50	50	50	50	50	50	50
Operating pressure, max.	PN	bar	16	16	16	16	16	16	16
Height	H1	mm	230	240	250	260	275	305	335
	H2	mm	75	85	95	105	120	135	180
Flange diameter	D	mm	165	185	200	220	250	285	340
Bolt circle diameter	D1	mm	125	145	160	180	210	240	295
Number of bolts	Pcs.		4	4	8	8	8	8	12
Bolt diameter		mm	19	19	19	19	19	23	23
Weight		kg	11	12	14	18	22	27	43,5

